

[www.bbcpl.in](http://www.bbcpl.in)



BluBoxx Communication Pvt. Ltd.

ISO 9001:2015 Certified Company



“We help you connect”

102/B, Surekha Apartment, Pune - Satara Road,  
Pune - 411037. Maharashtra, India.  
+91 78754 32180 | +91 91759 42186 | [sales@bbcpl.in](mailto:sales@bbcpl.in)

## Industrial Ethernet Switches



Un-Managed Ethernet Switch



Compact L-2 POE Switch



8+2 UnManaged Ethernet Switch



L-2, Managed Ethernet Switch



Full Gigabit Managed Ethernet Switch



IP67 Rated Ethernet Switch



Wall-Mount Ethernet Switch



Rack-Mount Ethernet Switch



## Specialized Ethernet Switches



Profinet Switch



IEC-61850 Switch



TSN Switch



EN50155 M12 Switch



L3 Managed 10G Switch



E-Mark Compliant Switch



Renewable Energy Switch

## Media Converters



SFP Modules



Serial to Fiber



Ethernet to Fiber



Ethernet Switch with FO Ports



Fiber Bypass Switch



## Fiber Optics & Networking Accessories



Single Mode FO Patch Cord



Multi Mode FO Patch Cord



Ethernet Patch Cord



Armored FO Patch Cord



Compact DIN RAIL Mount LIU

## Serial Device Servers



USB To RS-232/485/422



1-Port RS-232/485/422 to Ethernet



2-Port RS-232/485/422 to Ethernet



RS-232 to RS-485/422 Converter



8 Port 232/485/422 to Ethernet



16 Port 232/485/422 to Ethernet



Ethernet-Modbus Gateway to 4-Port RS-485/422

## Industrial PC & Monitor



Embedded Industrial Computer



Touch Panel PC



Barebone PC



IP69K Stainless Steel Panel PC



Fanless PC



Mini PC

## I-IOT Products



Modular industrial router MRX



TRB145



RUTX11



RUT955



RUT240

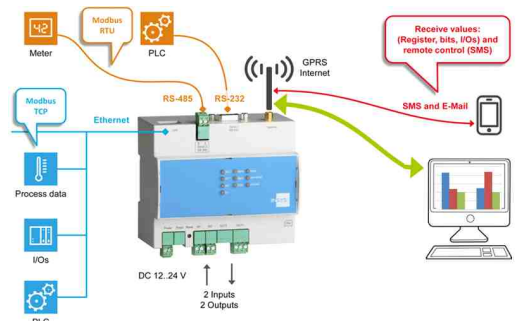

## Industrial Modems & Routers



SHDSL Switch



M2M Router



VPN Router

M2Me client



M2Me Server



RAS Machine Access Box

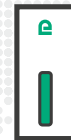

The M2Me client installed on the remote operator's PC, tablet or smart phone connects to the M2Me server (cloud-based solution operated by Etic Telecom) to establish a secure connection (VPN) onto the machine. It also organizes in a simple way the remote sites to be maintained or monitored.

The M2Me\_Connect service offers a secure end-to-end connection.

A Machine Access Box (industrial VPN Router) connects the machine or the remote industrial equipment to the M2Me server in a simple and totally secure way.

## Fieldbus Products

The Profibus Tester V5 is a Mobile Testing unit. It is a powerful diagnostic and troubleshooting tool for testing cables, measuring signals and analyzing communication of any LIVE Profibus networks. Combination of PROFIBUS Signal tester, Oscilloscope, Protocol analyzer, Master simulator & Cable tester functionality in a single handheld diagnostic tool.



Profinet Cable Stripper



Profinet Connector



Profibus Connector



Profibus Cable Stripper



Profibus HUB



Profibus Tester

## Protocol Converters



MPI To Ethernet



Modbus Gateway



CANopen To Modbus TCP Converter



Modbus-RTU To Profibus-DP Converter



Modbus-RTU/ASCII To ProfiNet Converter



M-Bus to Modbus (RS485) Converter



## Power Supply



24V/0.63A, 15W



48V/7.3A, 350W



24V/5A, 120W



24V/10A, 240W



24V/10A, 240W



48V/10A, 480W

## Communication Cable



CAT6



Profibus



Modbus



CANbus



Profinet



DeviceNet



LiCY

## Services & AMC

- Profibus Network Diagnosis
- Profinet Network Diagnosis
- Ethernet Network Diagnosis
- Fiber Optics Network Diagnosis
- PLC Programming & Logic Development
- HMI Programming & Logic Development
- PLC Migration & Retrofitting
- Fiber Optic Cable Splicing

